

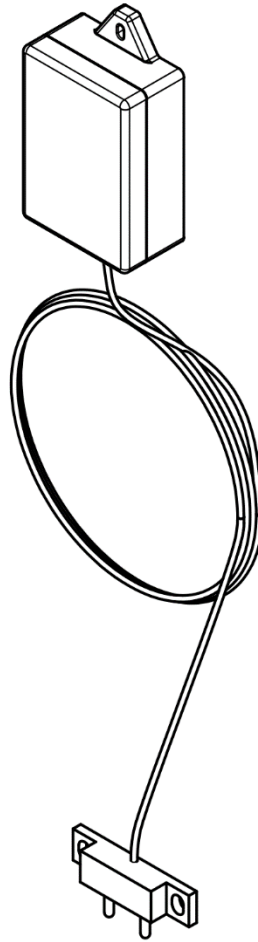

SENSORTECH



Hydro D Tech Monitor

User Manual

Version 1.0

December 31, 2024

Table of Contents

Table of Contents	iii
1. Introduction	4
1.1 Overview	4
2. Account and Notifications Setup.....	5
3. Installation	6
3.1 Installation Considerations	6
3.2 Included Hardware.....	6
3.3 Wood Stud Installation	7
3.3.1 Required Materials	7
3.3.2 Installation Procedure.....	8
3.4 Drywall Installation	10
3.4.1 Required Materials	10
3.4.2 Installation Procedure.....	11
3.5 Double Sided Tape Installation	13
3.5.1 Required Materials	13
3.5.2 Installation Procedure.....	14
4. Troubleshooting.....	16
4.1 Error Messages.....	16
5. Support	17
Appendix A: Light Indicator Patterns and Meanings	18
Revision History	19

1. Introduction

This user manual provides the information necessary for effectively installing and using the Hydro D Tech Monitor and the associated web platform.

1.1 Overview

The Hydro D Tech monitor remains inactive until water touches its exposed contacts; at which point it alerts the user via their preferred method of email or text.

The monitor's ultra-low power consumption ensures a battery life of several years, minimizing the need for maintenance.

The web-based user interface allows users to customize notifications and monitor the unit's health.

Users receive notification in the following scenarios: Water Presence, Low Battery, and Device Unresponsive. In addition, users can optionally receive periodic notifications confirming normal operation.

Note: The device requires 15 – 30 seconds of continuous water contact to activate and send a notification.

2. Account and Notifications Setup



1. Scan the provided QR code, or navigate to <https://dtech.sensortechllc.com/provision>
2. Follow the instructions on the screen to start the provisioning timer.
3. Use a #1 Phillips screwdriver to remove the clear case top.
4. Connect the provided battery, ensuring it is positioned near the center at the top, with the red and green LEDs clearly visible.
5. Reinstall the clear case top, tightening it securely with the screwdriver to ensure a watertight seal. Avoid over-tightening to prevent cracking.
6. Test cellular transmission by quickly coining the monitor (rubbing a metal object against the two small screws on the top left side of the case) until red AND green LED lights begin flashing. If the transmission is successful, you will be notified via text or email within 2 minutes. If you do not receive a notification after 2 minutes, move the monitor to a higher area with greater cellular strength and repeat Step 6.



3. Installation

3.1 Installation Considerations

The Hydro D Tech monitor can be installed in a variety of locations, depending on the perceived risk. Below are common installation areas:

- On an exterior basement wall for monitoring ground water ingress, particularly during heavy rainstorms.
- On a wall near the hot water heater to monitor for substantial leaks or burst pipes.
- On a support in the crawl space to monitor for burst pipes.
- In a sump well above the typical fill level to monitor for sump pump failure.

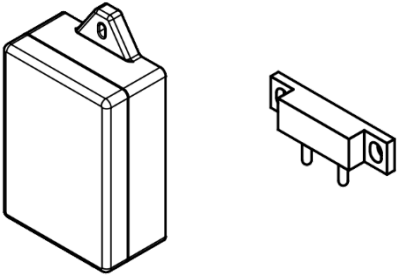
3.2 Included Hardware

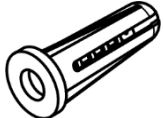
Ref. Number	Name	Qty.	Image
1 & 2	Hydro D Tech Monitor: Controller Case (1) & Sensor Case (2)*	1	
3	1" Wood Screws	2	
4	3/4" Wood Screws	2	
5	Drywall Anchors	2	





* The length of the cable between the Controller Case (1) and the Sensor Case (2) is approx. 84".

3.3 Wood Stud Installation

This is the recommended installation method and can be completed with the included hardware and a screwdriver. Drilling pilot holes is recommended but not required. Refer to Figure 1 for a visual guide.

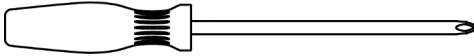
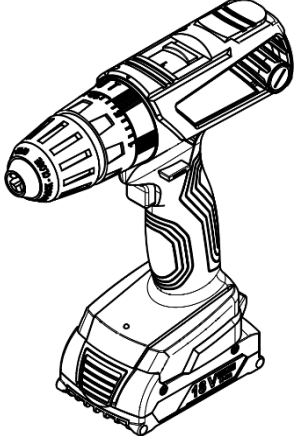
3.3.1 Required Materials

The following materials are not included but are required for completing this procedure.

Name	Image
#1 Phillips Screwdriver	
Recommended for Drilling Pilot Holes (Optional)	
Drill	
3/32" Drill Bit	
Pencil or Pen	
Recommended for Cable Management (Optional)	
Nail-in Wire Holder (Qty: 3+)	

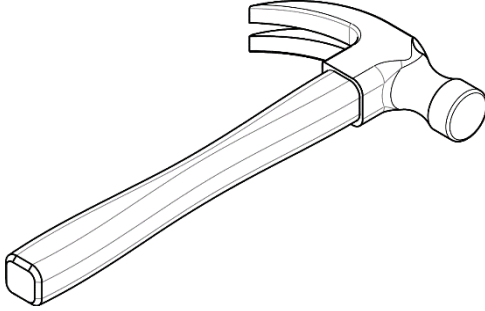
Name	Image
Hammer	

3.3.2 Installation Procedure

1. Place the Controller Case (1) against the wall at your desired location, ensuring the Sensor Case (2) can still reach the floor.
2. **Optional.** Drill pilot holes by first marking the center of each mounting hole with a pencil/pen. Next, use a drill equipped with a 3/32" drill bit to drill into the stud wall at each marked hole.
3. Using a flat head screwdriver, secure a 1" Wood Screw (3) through the top flange of the Controller Case (1) into the stud wall.
4. Repeat the step above to secure the bottom flange of the Controller Case (1) into the stud wall.
5. Position the Sensor Case (2) near the base of the wall, ensuring a small gap, roughly equivalent to the thickness of a credit card, is maintained between the sensor prongs and the floor.
6. **Optional.** Drill pilot holes by first marking the center of each mounting hole with a pencil/pen. Next, use a drill equipped with a 3/32" drill bit to drill into the stud wall at each marked hole.
7. Using a flat head screwdriver, secure a 3/4" Wood Screw (4) through the side flange of the Sensor Case (2) into the stud wall.
8. **Optional.** To secure cables, pull the cable tightly upwards from the Sensor Case (2) and center the Nail-in Wire Holder over the cable. Use a hammer to drive the Nail-in Wire Holder to the wall. Repeat as needed for additional cable support.
9. Using a flat head screwdriver, secure the remaining 3/4" Wood Screw (4) through the other side flange of the Sensor Case (2).

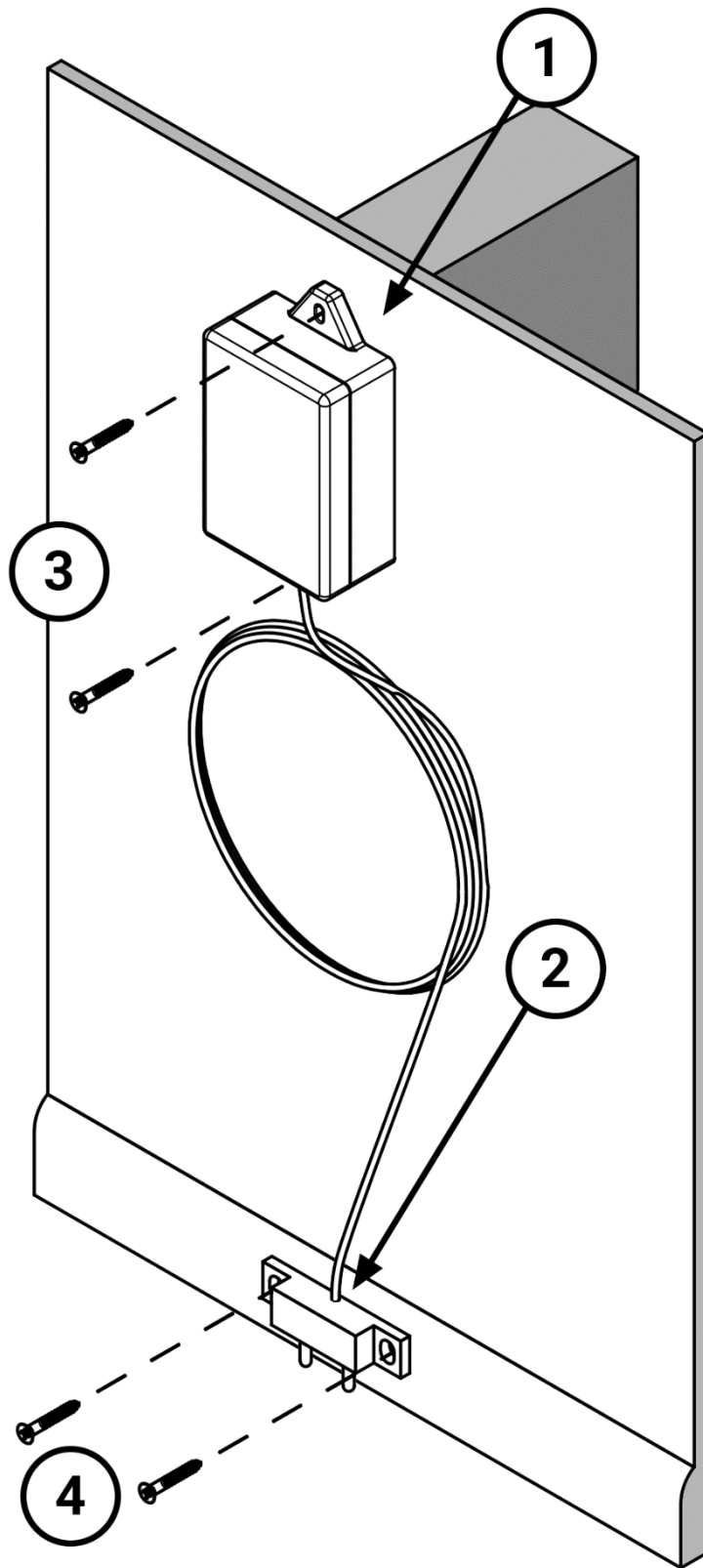

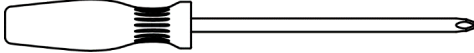
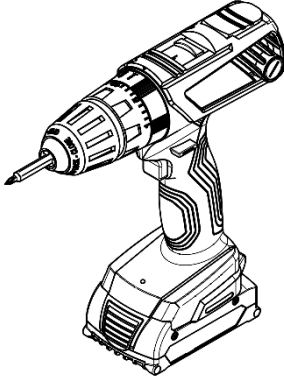



Figure 1: Wood Stud Installation (Recommended)

3.4 Drywall Installation

The Hydro D Tech monitor can be installed into drywall using the included hardware and a screwdriver. Refer to Figure 2 for a visual guide.

3.4.1 Required Materials

The following materials are not included but are required for completing this procedure.

Name	Image
#1 Phillips Head Screwdriver	
Drill	
3/16" Drill Bit	
Pencil or Pen	
Recommended for Drilling Pilot Holes (Optional)	
3/32" Drill Bit	
Recommended for Cable Management (Optional)	
Nail-in Wire Holder (Qty. 3+)	

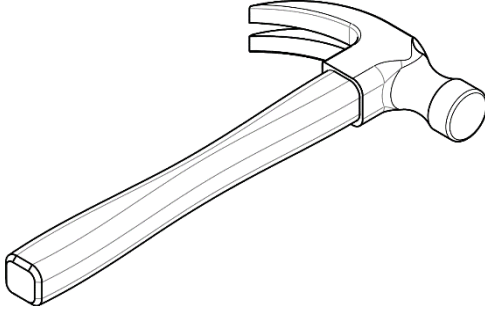
Name	Image
Hammer	

3.4.2 Installation Procedure

1. Place the Controller Case (1) against the wall at your desired location, ensuring the Sensor Case (2) can still reach the floor.
2. Mark the center of each mounting hole with a pencil/pen.
3. Use a drill equipped with a 3/16" drill bit to drill into the drywall at each marked hole.
4. Gently push the Drywall Anchors (5) into each hole until they are flush with the wall.
5. Using a flat head screwdriver, secure a 1" Wood Screw (3) through the top flange of the Controller Case (1) into the top drywall anchor.
6. Repeat the step above to secure the bottom flange of the Controller Case (1) into the bottom drywall anchor.
7. Position the Sensor Case (2) near the base of the wall, ensuring a small gap, roughly equivalent to the thickness of a credit card, is maintained between the sensor prongs and the floor.
8. **Optional.** Drill pilot holes by first marking the center of each mounting hole with a pencil/pen. Next, use a drill equipped with a 3/32" drill bit to drill into the wall/baseboard at each marked hole.
9. Using a flat head screwdriver, secure a 3/4" Wood Screw (4) through the side flange of the Sensor Case (2) into the wall/baseboard.
10. **Optional.** To secure cables, pull the cable tightly upwards from the Sensor Case (2) and center the Nail-in Wire Holder over the cable. Use a hammer to drive the Nail-in Wire Holder to the wall. Repeat as needed for additional cable support.
11. Using a flat head screwdriver, secure the remaining 3/4" Wood Screw (4) through the other side flange of the Sensor Case (2).

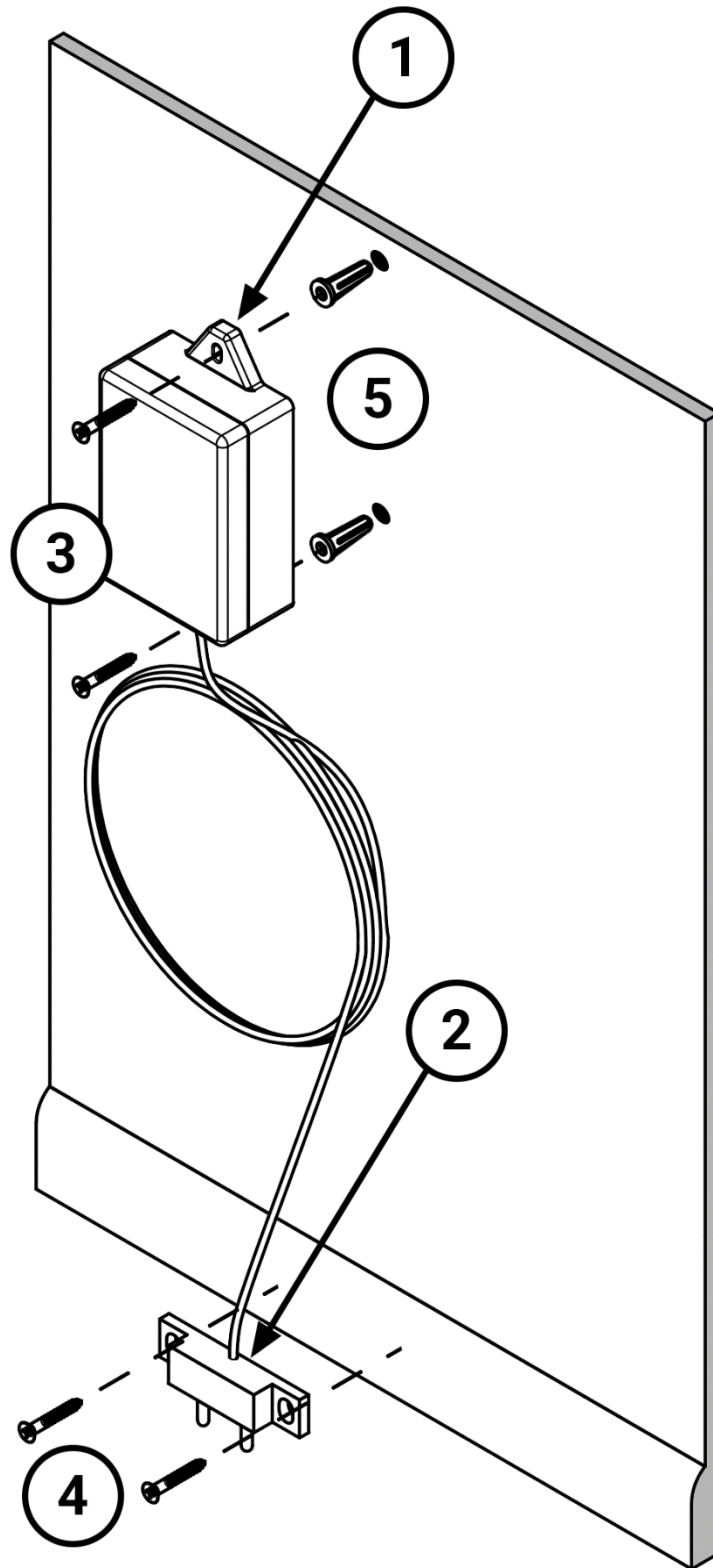

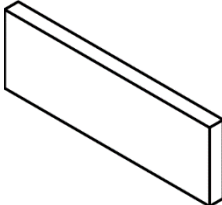

Figure 2: Drywall Installation

3.5 Double Sided Tape Installation

The Hydro D Tech monitor can be installed onto a clean surface using double sided (not included). Refer to Figure 3 for a visual guide.

3.5.1 Required Materials

The following materials are not included but are required for completing this procedure.

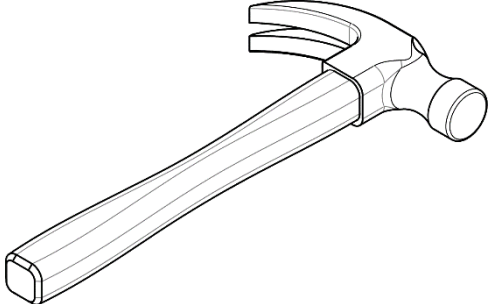
Name	Image
0.5" x 1.5" Double Sided Tape (Qty. 2)	
Recommended for Cable Management (Optional)	
Nail-in Wire Holder (Qty. 3+)	
Hammer	

3.5.2 Installation Procedure

1. Prior to beginning the installation, ensure the surface to which you intend to mount the cases is clean and free of dust as it will interfere with the adhesion of the double-sided tape.
2. Choose a spot on the wall for mounting the Controller Case (1), ensuring the Sensor Case (2) can still reach the floor.
3. Remove the backing from one side of the double-sided tape pieces.
4. Adhere the sticky side of the tape to the back of the Controller Case (1).
5. Remove the backing from the other side of the same tape piece.
6. Press the Controller Case (1) firmly against the wall in the location chosen in Step 2.
7. Position the Sensor Case (2) near the base of the wall, ensuring a small gap, roughly equivalent to the thickness of a credit card, is maintained between the sensor prongs and the floor.
8. Using the remaining double-sided tape piece, remove the backing from one side.
9. Adhere the sticky side of the tape to the back of the Sensor Case (2).
10. Remove the backing from the other side of the same tape piece.
11. Press the Sensor Case (2) firmly against the wall in the location chosen in Step 2.
12. **Optional.** To secure cables, pull the cable tightly upwards from the Sensor Case (2) and center the Nail-in Wire Holder over the cable. Use a hammer to drive the Nail-in Wire Holder to the wall. Repeat as needed for additional cable support.

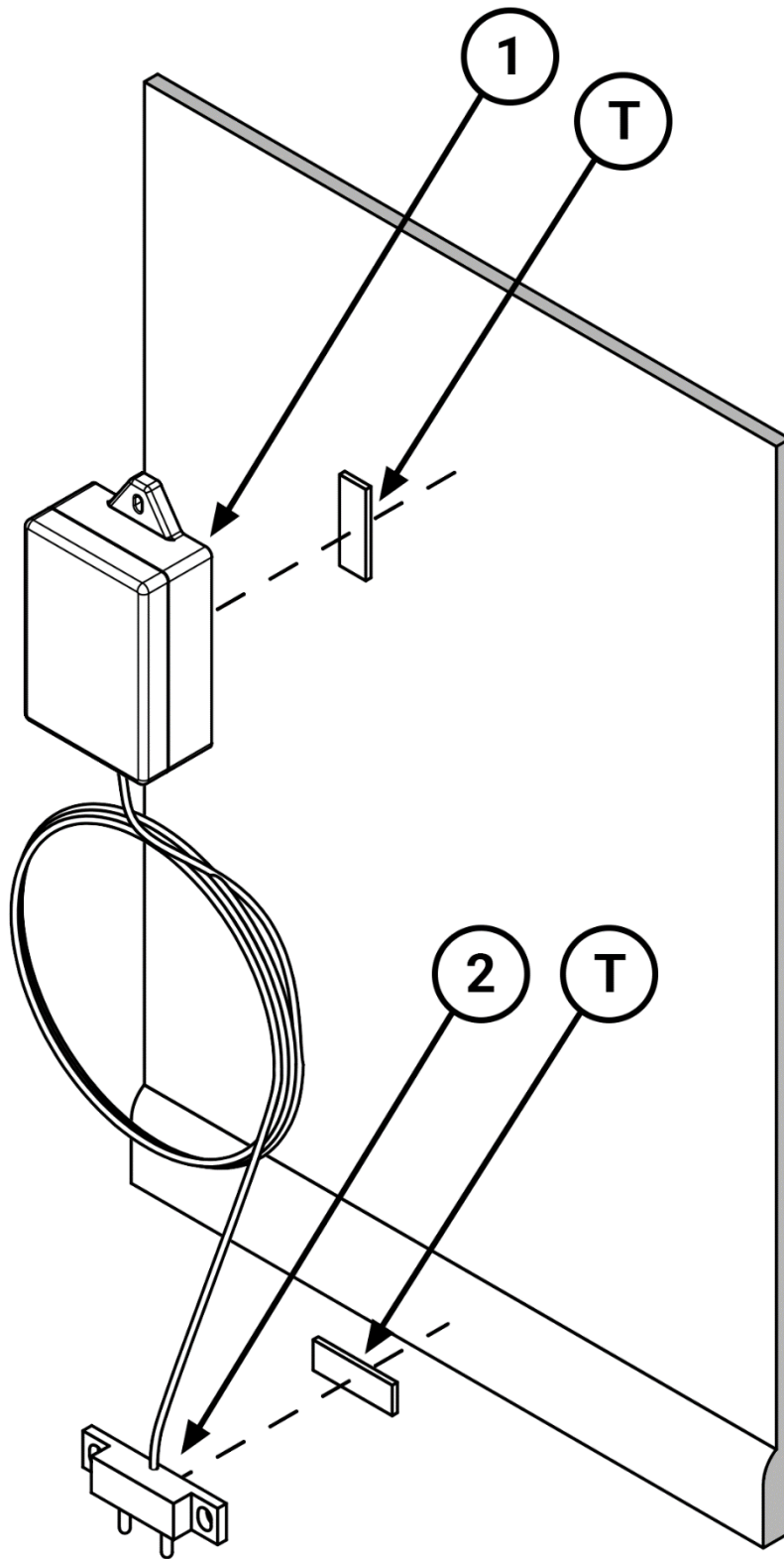

Figure 3: Double-Sided Tape Installation

4. Troubleshooting

4.1 Error Messages

Below is a list of error messages a user may encounter. If an error occurs, a series of red flashes will display after 10 quick red flashes, indicating failed transmissions.

Number of Red Flashes	Meaning	Action Required
1	Hardware issue	Contact SensorTech, LLC Support or return the unit if within the 12-month warranty period.
2	SIM card issue	Verify SIM card is properly installed. If issue persists after several attempts, contact SensorTech, LLC Support or return the unit if within the 12-month warranty period.
3	Network error	Move the unit to a different location with better signal strength and try again. If problem persists after several attempts, contact SensorTech, LLC Support.
4	Network error	If problem persists after several attempts, contact SensorTech, LLC Support.
5	Connection error	If problem persists after several attempts, contact SensorTech, LLC Support.
6	Connection error	If problem persists after several attempts, contact SensorTech, LLC Support.
7	Low battery	Replace battery and try again.
8	Network error	If problem persists after several attempts, contact SensorTech, LLC Support.

5. Support

Please contact SensorTech, LLC for support or with any questions.

SensorTech, LLC: 316.267.2807 | support@sensortechllc.com

Appendix A: Light Indicator Patterns and Meanings

Pattern	Meaning
Alternating red and green flashes	The unit registered a change in state or presence of water and initiated a notification.
10 rapid green flashes	The unit successfully sent a notification.
Some rapid green flashes followed by several rapid red flashes	The unit tried to send a notification but was unable to establish a reliable signal

Revision History

Version	Date	Description of Change
1.0	12/31/24	Initial version.